

**Instructions**

- 1- Position mounting board as shown in drawing.
- 2- Drill holes in mounting board.
- 3- Using the holes you have just drilled, mark the mounting surface below.
- 4-Using a 25/64" drill bit to make a 1/8" deep pilot hole for the insert.
- 5- Use one of the thumb screws provided and screw the insert to depth. The insert must be flush or slightly with the top of the mounting surface
- 6- Place washer and thumb screw over the hole and tighten so the mounting board is secured and cannot move in any direction.

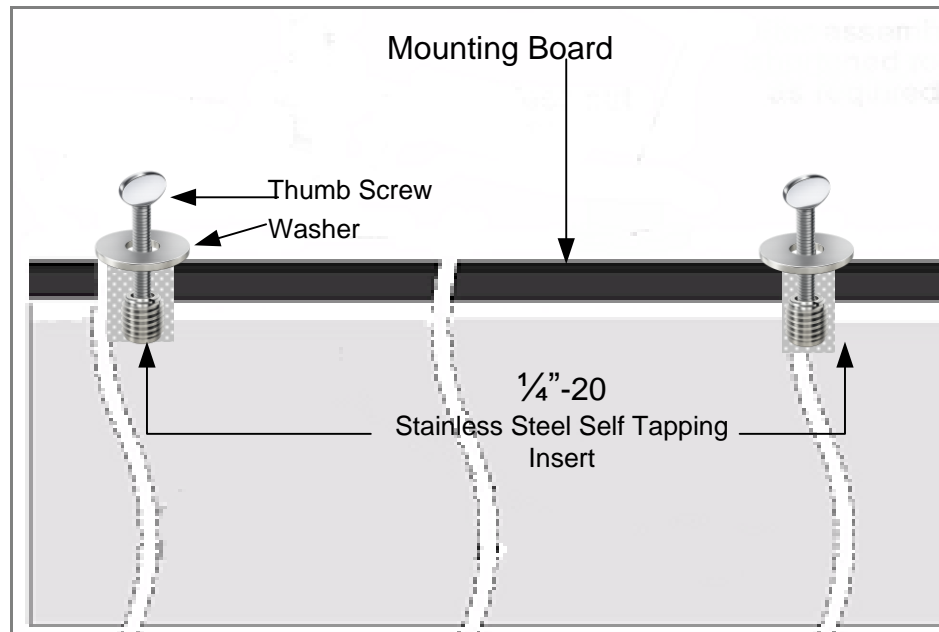

Threaded Insert Type	Tapping
Material	18-8 Stainless Steel
Thread Size	1/4"-20
Installed Length	0.500"
Drill Bit Size	25/64"
For Maximum Hole Diameter	0.391"
Drive Style	Slotted
End Type	Open

